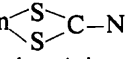

Å respectively. In the *B* ion the two S—C bond lengths are nearly equal, and the two Zn—S bonds lie approximately in the ligand plane. Thus the Zn —C—N group makes a conjugate system. Within the *A* ion, however, the S(1)—C(1) bond is significantly longer than S(2)—C(1). This is consistent with the fact that the S(1) atom is bonded to two Zn atoms with a shorter S(1)—Zn' bond out of the ligand plane and a longer S(1)—Zn bond lying in the plane. Thus the π -bond character seems to be localized on the S(2)—C(1) bond.

The calculations were made on a FACOM 230-75 computer of this Institute using the UNICS II program system (Sakurai, Iwasaki, Watanabe, Kobayashi,

Bando & Nakamichi, 1974). Part of this work was supported by a Grant-in-Aid for Scientific Research No. 354161 from the Ministry of Education, Science and Culture.

References

- BONAMICO, M., MAZZONE, G., VACIAGO, A. & ZAMBONELLI, L. (1965). *Acta Cryst.* **19**, 898–909.
International Tables for X-ray Crystallography (1974). Vol. IV. Birmingham: Kynoch Press.
 KLUG, H. P. (1966). *Acta Cryst.* **21**, 536–546.
 SAKURAI, T., IWASAKI, H., WATANABE, Y., KOBAYASHI, K., BANDO, Y. & NAKAMICHI, Y. (1974). *Rep. Inst. Phys. Chem. Res.* **50**, 75–91.

Acta Cryst. (1979). **B35**, 1482–1486

α -L-Xylopyranose: A Neutron Diffraction Refinement*

BY SHOZO TAKAGI† AND G. A. JEFFREY

Department of Chemistry, Brookhaven National Laboratory, Upton, New York 11973, USA and Department of Crystallography, University of Pittsburgh, Pittsburgh, Pennsylvania 15260, USA

(Received 21 November 1978; accepted 30 January 1979)

Abstract. The crystal structure of α -L-xylopyranose, C₅H₁₀O₅, has been refined with neutron diffraction data collected at two different wavelengths. The anisotropic extinction corrections derived for the two wavelengths agreed within 1 σ . The heavy-atom coordinates are in good agreement with those from a previous X-ray study [Hordvik (1971). *Acta Chem. Scand.* **25**, 2175–2182]. The more accurate unit-cell data (298 K) are $a = 9.213$ (1), $b = 12.639$ (1), $c = 5.618$ (1) Å ($\lambda = 1.54051$ Å), $V = 654.18$ Å³, $M_r = 150.13$, space group $P2_12_12_1$, $Z = 4$, $D_c = 1.524$ Mg m⁻³. The hydrogen bonding consists of a finite chain which originates at the anomeric hydroxyl and terminates at the ring oxygen, with H...O distances ranging from 1.731 to 1.843 Å. The conformation of the pyranose ring is unusual in that it is a perfect ¹C₄ (L) chair.

Introduction. This refinement forms part of a neutron-diffraction study of carbohydrates aimed at providing the accurate data relating to the hydrogen-atom positions which are necessary to understand the rules which govern the stereochemistry of the hydrogen

bonding in the crystal structures of polyhydric molecules (*cf.* Jeffrey & Takagi, 1978).

α -L-Xylopyranose was obtained from Sigma Chemical Company. Transparent crystals suitable for single-crystal neutron diffraction were grown by slow evaporation of a 95% ethanol–water solution at room temperature. The crystal and experimental data and the structure refinement parameters are given in Table 1.

Cell constants and three-dimensional neutron diffraction data were collected with wavelengths 1.0541 [data set (I)] and 1.1604 Å [data set (II)] at room temperature on the Brookhaven High-Flux Beam Reactor single-crystal diffractometer as described by Takagi & Jeffrey (1977a).

The atomic coordinates from the X-ray determination (Hordvik, 1971) were used as the initial values for separate refinement of (I) and (II) by full-matrix least squares, minimizing $\sum w|F_o^2 - k^2 F_c^2|^2$ (Busing, Martin & Levy, 1962). A difference Fourier map revealed the positions of all hydrogen atoms. The refinement parameters and neutron scattering lengths used are defined in Takagi & Jeffrey (1977a). The final anisotropic extinction parameters for (I) and (II) agree within the σ 's for one of the sets, indicating that these parameters are indeed a property of the crystal rather than of the experiment. The final positional parameters are listed in Table 2. The two sets of refined parameters agree within 2.5 σ , those of (I) being the more

* Research supported by NIH Grants GM-21794 and GM-24526, and performed under the auspices of the US Energy Research and Development Administration.

† Present address: American Dental Association, Health Foundation Research Unit, National Bureau of Standards, Washington, DC 20234, USA.

Table 1. Crystal data, neutron diffraction experimental and refinement parameters of α-L-xylopyranose

Crystal data		
	(I)	(II)
λ (neutron)	1.0514 Å	1.1604 Å
a	9.220 (2) Å	9.227 (2) Å
b	12.633 (2)	12.643 (3)
c	5.618 (2)	5.619 (2)
Experimental and refinement data		
	(I)	(II)
Crystal weight		0.0162 g
Crystal volume		10.67 mm ³
Crystal faces	(10̄0) (1̄10) (001) (01̄1) (111) (102)	(105) (270) (290)
Number of reflections:		
Total measured	1583 (hkl octant)	1114 (hkl octant)
Unique	1510	1045
	[128 with $F_o^2 \leq \sigma(F_o^2)$]	[57 with $F_o^2 \leq \sigma(F_o^2)$]
Data collection mode,	θ-2θ step scan, fixed width 3.0° for	
scan width	2θ ≤ 60°; variable width calculated by 0.9° + 3.87° tan θ for 60° < 2θ ≤ 110° and 60° < 2θ ≤ 105° for (I) and (II), respectively	
Absorption correction:		
(Templeton & Templeton, 1973)		
μ (neutron)	0.2446 mm ⁻¹	
Max. corr. to F_o^2	1.633	1.627
Min. corr. to F_o^2	1.466	1.465
Av. corr. to F_o^2	1.531	1.530
Final refinement:		
Number of reflections, n	1510	1045
Number of variables, m	187	187
Function minimized	$\sum w F_o^2 - k^2 F_c^2 ^2$	
w^{-1}	$\sigma_o^2(F_o^2) + (0.020F_o^2)^2$ $\sigma_c^2(F_c^2) + (0.022F_c^2)^2$	
	where σ_c is from counting statistics	
R_F^2	0.036	0.029
wR_F^2	0.046	0.043
Goodness of fit, S	1.073	1.155
Anisotropic extinction (× 10 ⁴):*		
(Becker & Coppens, 1975)		
g ₁₁	102 (18)	84 (14)
g ₂₂	78 (21)	75 (17)
g ₃₃	18 (3)	14 (2)
g ₁₂	-79 (18)	-62 (13)
g ₁₃	1 (8)	14 (5)
g ₂₃	5 (8)	2 (6)
	One reflection (002) is affected by extinction, E = 0.74 and 0.71 for (I) and (II), respectively.	

* Type 1, Lorentzian distribution, anisotropy of mosaic spread according to Thornley & Nemes (1974).

accurate, presumably because of the greater number of observations.*

The atomic notation and molecular dimensions are shown in Fig. 1 for data refinement (I). Calculation of distances and angles with their estimated standard deviations was made with the variance-covariance matrix (Busing, Martin & Levy, 1964), with the more accurate X-ray values of the cell dimensions, which

* Tables of anisotropic thermal parameters, structure factors, and the results of a rigid-body motion analysis have been deposited with the British Library Lending Division as Supplementary Publication No. SUP 34238 (35 pp.). Copies may be obtained through The Executive Secretary, International Union of Crystallography, 5 Abbey Square, Chester CH1 2HU, England.

were remeasured, since the values reported by Hordvik (1971) were 0.3% greater than the neutron diffraction values. The contents of the unit cell are shown in Fig. 2. Results of a rigid-body thermal-motion analysis* (Schomaker & Trueblood, 1968) gave ⟨r.m.s. |U_{ij} - U_{i/RMB}⟩ = 0.0005 and 0.0006 Å for (I) and (II), respectively, based on a rigid-body model (A) consisting of the six ring atoms, and 0.0019 and 0.0018 Å based

* See previous footnote.

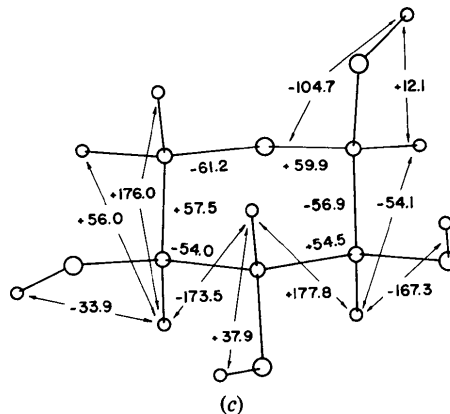
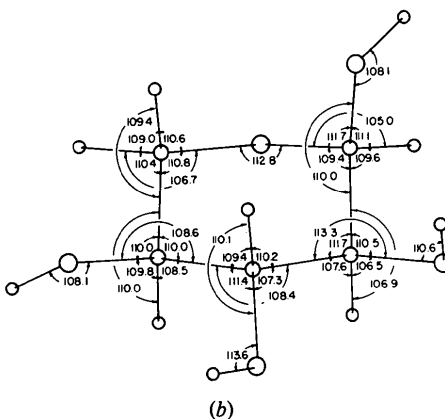
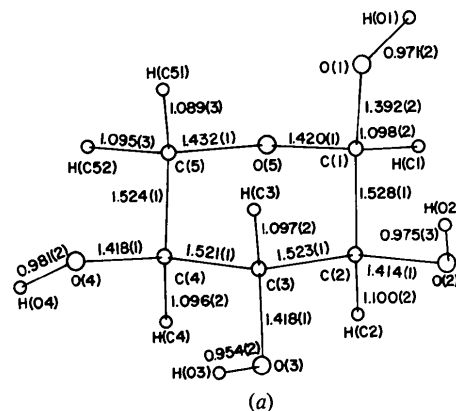

Fig. 1. Molecular dimensions (Å and deg.) of α-L-xylopyranose (I). The σ's for bond angles and torsion angles are 0.1°, except for angles involving one C(1)-H, C(5)-H, O-H bond where it is 0.2°, and two of these bonds where it is 0.3°.

Table 2. *The final fractional coordinates ($\times 10^5$) for α -L-xylopyranose*

	(I)			(II)		
	<i>x</i>	<i>y</i>	<i>z</i>	<i>x</i>	<i>y</i>	<i>z</i>
C(1)	57030 (10)	48636 (6)	43867 (18)	57028 (11)	48638 (7)	43848 (20)
C(2)	64193 (9)	39773 (6)	29581 (17)	64196 (10)	39775 (7)	29560 (19)
C(3)	54876 (9)	29820 (6)	29166 (17)	54898 (10)	29812 (7)	29205 (19)
C(4)	39871 (9)	32769 (6)	20048 (17)	39872 (11)	32750 (7)	20058 (19)
C(5)	33647 (10)	41816 (7)	34807 (22)	33648 (11)	41815 (8)	34759 (24)
O(1)	56226 (15)	45814 (9)	67773 (23)	56233 (16)	45825 (10)	67768 (26)
O(2)	78489 (12)	37954 (9)	37790 (25)	78488 (13)	37953 (13)	37756 (27)
O(3)	61796 (14)	22461 (8)	13857 (28)	61771 (15)	22460 (9)	13882 (30)
O(4)	30753 (12)	23766 (8)	21797 (22)	30704 (13)	23772 (9)	21789 (24)
O(5)	43094 (12)	50809 (7)	34227 (26)	43111 (13)	50812 (8)	34263 (28)
H(C1)	63198 (27)	55993 (14)	41540 (47)	63231 (27)	55973 (15)	41540 (50)
H(C2)	65173 (25)	42617 (16)	11137 (38)	65161 (26)	42612 (17)	11138 (41)
H(C3)	53940 (22)	26510 (16)	47149 (39)	53922 (23)	26500 (16)	47198 (42)
H(C4)	40840 (28)	35191 (17)	1376 (39)	40850 (30)	35176 (18)	1359 (42)
H(C51)	31998 (28)	39156 (20)	53049 (49)	31989 (28)	39191 (21)	53120 (52)
H(C52)	23234 (25)	44403 (19)	27436 (66)	23293 (26)	44424 (20)	27511 (67)
H(O1)	59506 (26)	51791 (18)	77207 (43)	59460 (27)	51798 (20)	77097 (45)
H(O2)	78357 (22)	33956 (16)	52621 (42)	78384 (24)	33954 (17)	52562 (46)
H(O3)	59082 (25)	15295 (14)	16782 (53)	59113 (26)	15324 (17)	16781 (56)
H(O4)	23239 (22)	24333 (15)	9500 (44)	23247 (23)	24357 (17)	9585 (48)

on a model (*B*) which included all the carbon and oxygen atoms. The thermal-motion corrections to the bond lengths, made for model *B*, are given in Table 3, together with the riding-motion corrections (Busing & Levy, 1964) for the C—H and O—H bond lengths.

The molecular dimensions from the two refinements agree within 0.002 Å and 0.2°, except for C(5)—H(C51), C(5)—H(C52), O(3)—H(O3) and O(4)—H(O4), where the differences are 0.005, 0.007, 0.005 and 0.008 Å, and C(3)—C(4)—O(4), C(4)—C(5)—H(C52), and O(5)—C(5)—H(C51) with differences of 0.3, 0.4, and 0.5°. The results from refinement (I), which are given in Fig. 1, are used in the following discussion.

Discussion. The pyranose ring conformation is that of a perfect 1C_4 (L) chair, with Cremer & Pople (1975) puckering parameters of $Q = 0.575$ Å, $\theta = \phi = 0^\circ$. The only other example of a perfect pyranose chair hitherto reported is found in the crystal structure of methyl α -D-

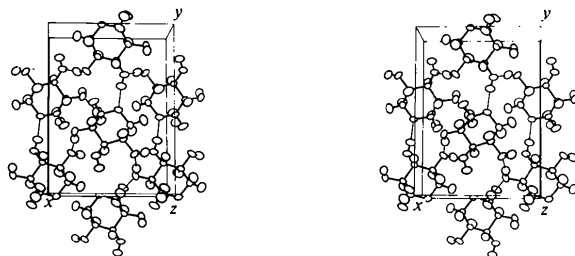
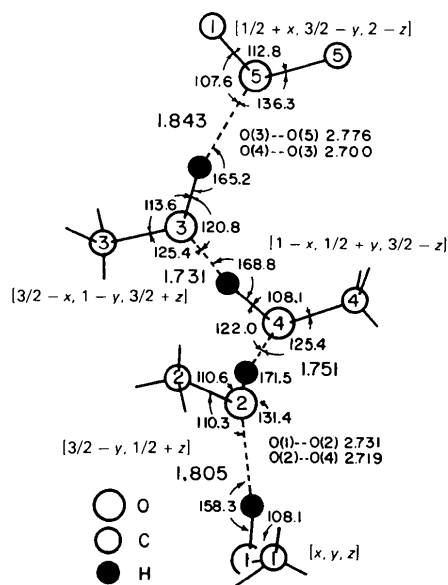

Fig. 2. Unit-cell contents in α -L-xylopyranose (I). The thermal ellipsoids are at 50% probability (Johnson, 1976).

mannopyranoside (Jeffrey, McMullan & Takagi, 1977). The ring C—C bond lengths differ by 0.007 Å (7σ) with a mean value of 1.5240 Å. Because of the constraint of ring closure, these bonds are not expected to be exactly equal (*cf.* Dunitz & Waser, 1972). The C—OH bond lengths, excluding those involved in the hemi-acetal system, differ by 0.004 Å (4σ) with a mean value of 1.4167 Å. The C—H bond lengths differ by 0.011 Å (5σ) with a mean value of 1.0958 Å. The O—H bond lengths extend over a wider range, from



O(1)H—O(2)H—O(4)H—O(3)H—O(5)

Fig. 3. Hydrogen bonding in α -L-xylopyranose (I).

Table 3. *Thermal-motion corrections (Å) in α -L-xylopyranose*

	Rigid-body thermal motion*		Riding motion† (lower bound)		Riding motion†	
	(I)	(II)	(I)	(II)	(I)	(II)
	C—C	0.007	0.007			
C—O	0.005	0.005				
C—H (on ring)	0.004	0.004	0.005	0.005	0.025	0.024
O—H			0.001	0.001	0.010	0.011

* Using model *B* consisting of the six atoms of the pyranose ring and atoms O(1), O(2), O(3) and O(4) (Schomaker & Trueblood, 1968).

† See Busing & Levy (1964) for definition.

Table 4. *Geometry of hydrogen bonding for anomeric hydroxyls in pyranose molecules from neutron diffraction data*

	Type*	O—H (Å)	H...O (Å)	O—H...O (°)	Reference
α -L-Rhamnose	<i>I</i>	0.979	1.740	174	Takagi & Jeffrey (1978)
β -D-Fructose	<i>I</i>	0.979	1.750	152	Takagi & Jeffrey (1977a)
α -L-Xylose	<i>F</i>	0.971	1.805	158	This work
β -D,L-Arabinose	<i>S</i>	0.971	1.811	169	Takagi, Nordenson & Jeffrey (1979)
β -L-Arabinose	<i>S</i>	0.952	1.820	170	Takagi & Jeffrey (1977b)
α -L-Sorbose	<i>I</i>	0.969	1.882	157	Nordenson, Takagi & Jeffrey (1978)
α -D-Glucose	<i>S</i>	0.970	1.915	161	Brown & Levy (1979)

* See Jeffrey & Takagi (1978). *I* infinite chain, *F* finite chain, *S* single link to O(5).

0.954 to 0.981 Å, and there is an apparent inverse correlation between the O—H and H...O bond lengths. However, in α -D-glucose (Brown & Levy, 1979) a more sophisticated treatment of the thermal-motion correction resulted in O—H distances which agreed within 0.012 Å, although the corresponding H...O distances differed by 0.15 Å. We believe therefore that the variations we observed may be due to thermal motion rather than differences in electronic structure. The bond lengths and valence angles in the hemi-acetal sequence C(5)—O(5)—C(1)—O(1)H are in good agreement with those observed in other α -pyranose sugars and with the results of *ab initio* MO calculations relating to the anomeric effect (Jeffrey, Pople, Binkley & Vishveshwara, 1978).

The hydrogen bonding consists of a finite chain originating at the anomeric hydroxyl O(1)—H and terminating at the ring oxygen O(5), as deduced by Hordvik (1971) from the X-ray analysis. The more precise geometry provided by this neutron analysis is shown in Fig. 3. The anomeric hydrogen-bond length of 1.805 Å is consistent with the concept that this bond is stronger than a non-anomeric hydrogen bond (Tse & Newton, 1977), but not as strong as when it forms part of an infinite chain and the hydroxyl is also a hydrogen-bond acceptor (see Table 4). An unusual feature of this structure is the very short bonds in the middle of the finite chain, as compared, for example, with the mean value of 1.815 Å for 23 neutron diffraction observations for hydrogen bonds of this type (see Jeffrey & Takagi, 1978). At present, we have no explanation for

this observation; however, it should be noted that a compression of 0.1 Å from the 'optimum value' of a hydrogen-bond length only involves a strain energy of about 2.0934×10^3 J mol⁻¹ (Jeffrey, 1979).

References

- BECKER, P. J. & COPPENS, P. (1975). *Acta Cryst.* **A31**, 417–425.
- BROWN, G. M. & LEVY, H. A. (1979). *Acta Cryst.* **B35**, 656–659.
- BUSING, W. R. & LEVY, H. A. (1964). *Acta Cryst.* **17**, 142–146.
- BUSING, W. R., MARTIN, K. O. & LEVY, H. A. (1962). *ORFLS*. Report ORNL-TM-305. Oak Ridge National Laboratory, Tennessee.
- BUSING, W. R., MARTIN, K. O. & LEVY, H. A. (1964). *ORFFE*. Report ORNL-TM-306. Oak Ridge National Laboratory, Tennessee.
- CREMER, D. & POPLE, J. A. (1975). *J. Am. Chem. Soc.* **97**, 1354–1358.
- DUNITZ, J. D. & WASER, J. (1972). *J. Am. Chem. Soc.* **94**, 5645–5650.
- HORDVIK, A. (1971). *Acta Chem. Scand.* **25**, 2175–2182.
- JEFFREY, G. A. (1979). *Proceedings of the Organic Crystal Chemistry Symposium, Poznań*. In the press.
- JEFFREY, G. A., MCMULLAN, R. K. & TAKAGI, S. (1977). *Acta Cryst.* **B33**, 728–737.
- JEFFREY, G. A., POPLE, J. A., BINKLEY, J. S. & VISHVESHWARA, S. (1978). *J. Am. Chem. Soc.* **100**, 373–379.
- JEFFREY, G. A. & TAKAGI, S. (1978). *Acc. Chem. Res.* **11**, 264–270.

- JOHNSON, C. K. (1976). *ORTEP-II*. Report ORNL-5138. Oak Ridge National Laboratory, Tennessee.
- NORDENSON, S., TAKAGI, S. & JEFFREY, G. A. (1978). *Acta Cryst.* B34, 3809–3811.
- SCHOMAKER, V. & TRUEBLOOD, K. N. (1968). *Acta Cryst.* B24, 63–76.
- TAKAGI, S. & JEFFREY, G. A. (1977a). *Acta Cryst.* B33, 3510–3515.
- TAKAGI, S. & JEFFREY, G. A. (1977b). *Acta Cryst.* B33, 3033–3040.
- TAKAGI, S. & JEFFREY, G. A. (1978). *Acta Cryst.* B34, 2551–2555.
- TAKAGI, S., NORDENSON, S. & JEFFREY, G. A. (1979). *Acta Cryst.* B35, 991–993.
- TEMPLETON, L. K. & TEMPLETON, D. H. (1973). Abstr. E10, Am. Crystallogr. Assoc. Meeting, Storrs, Connecticut.
- THORNLEY, F. R. & NELMES, R. J. (1974). *Acta Cryst.* A30, 748–757.
- TSE, Y.-C. & NEWTON, M. D. (1977). *J. Am. Chem. Soc.* 99, 611–613.

Acta Cryst. (1979). B35, 1486–1488

The Structure of Haloperidol Hydrobromide {4-[4-(4-Chlorophenyl)-4-hydroxypiperidino]-4'-fluorobutyrophenone HBr}

BY NARAYANDAS DATTA†, PANCHALI MONDAL* AND PETER PAULING

William Ramsay, Ralph Forster, and Christopher Ingold Laboratories, University College London, Gower Street, London WC1, England

(Received 20 November 1978; accepted 22 February 1979)

Abstract. $C_{21}H_{24}ClFNO_2^+ \cdot Br^-$, $M_r = 456.8$, monoclinic, $P2_1/c$, $a = 17.162(9)$, $b = 10.064(5)$, $c = 13.884(8)$ Å, $\beta = 118.40(4)^\circ$, $Z = 4$, $D_c = 1.44$ Mg m^{-3} , $V = 2109.4$ Å³. The final full-matrix least-squares refinement gave $R = 0.078$. Though the unit cells differ, the observed conformation is very similar to that of the analogous substance R1616, but differs from those observed in the free bases.

Introduction. Haloperidol hydrobromide (R2420) is a very potent (average dose 3 mg a day) neuroleptic drug (Janssen, 1967). The structure of haloperidol base (R1625), $C_{21}H_{23}ClFNO_2$, was determined by Reed & Schaefer (1973) and those of the closely related 4'-fluoro-4-[4-(4-fluorophenyl)-4-hydroxypiperidino]-butyrophenone, $C_{21}H_{23}F_2NO_2$ (R1616 base), and its hydrochloride, $C_{21}H_{24}F_2NO_2^+ \cdot Cl^-$ (R1616), were analysed by Koch & Germain (1972). The crystal structure of haloperidol hydrobromide was determined to investigate the analogies and differences among the three-dimensional structures of these butyrophenone, psychotropic drugs, primarily to gain additional observed data on the flexibility of the conformational degrees of freedom of these substances.

Crystals of haloperidol hydrobromide were provided by Paul Janssen. The thin, colourless, plate crystals were recrystallized from a methanol 5% water mixture. Laue symmetry and preliminary cell parameters were determined from oscillation and precession photo-

graphs. The refined cell parameters and their e.s.d.'s were obtained by a least-squares refinement of the angular parameters of 12 diffraction maxima measured with a peak-finding technique on a computer-controlled four-circle Stoe diffractometer (Busing, Ellison, Levy, King & Rosebury, 1968).

Three-dimensional X-ray diffraction data were collected on the diffractometer using Mo $K\alpha$ radiation (graphite monochromator), a coupled θ - 2θ step-scan with $\Delta 2\theta = 0.04^\circ$, a counting time of 8 s per step and a peak width of 1.6° . A standard reflection was measured every 25 measurements. In the range $2\theta = 5$ – 45° , 3244 maxima (being one quadrant of reciprocal space) were measured, of which 2031 observed, unique maxima [$I \geq 3\sigma(I)$] were used to determine and refine the structure. The data were corrected for Lorentz and polarization effects, but not for absorption or extinction.

The position of the Br ion was determined from a Patterson synthesis. An observed Fourier synthesis phased on the Br ion produced a satisfactory partial, trial structure. A second Fourier synthesis phased on this trial structure revealed all non-hydrogen atoms. Successive cycles of full-matrix least-squares refinement of positional and isotropic thermal parameters for the non-hydrogen atoms gave $R = 0.125$ and further cycles of anisotropic, full-matrix refinement of all non-hydrogen atoms converged to an R value of 0.083. At this stage the 24 H atom positions were included in positions calculated using accepted geometrical parameters. H atoms were included in further refinements (but

† Deceased 17 June 1976.

* To whom correspondence should be addressed.